

Boden / bottom

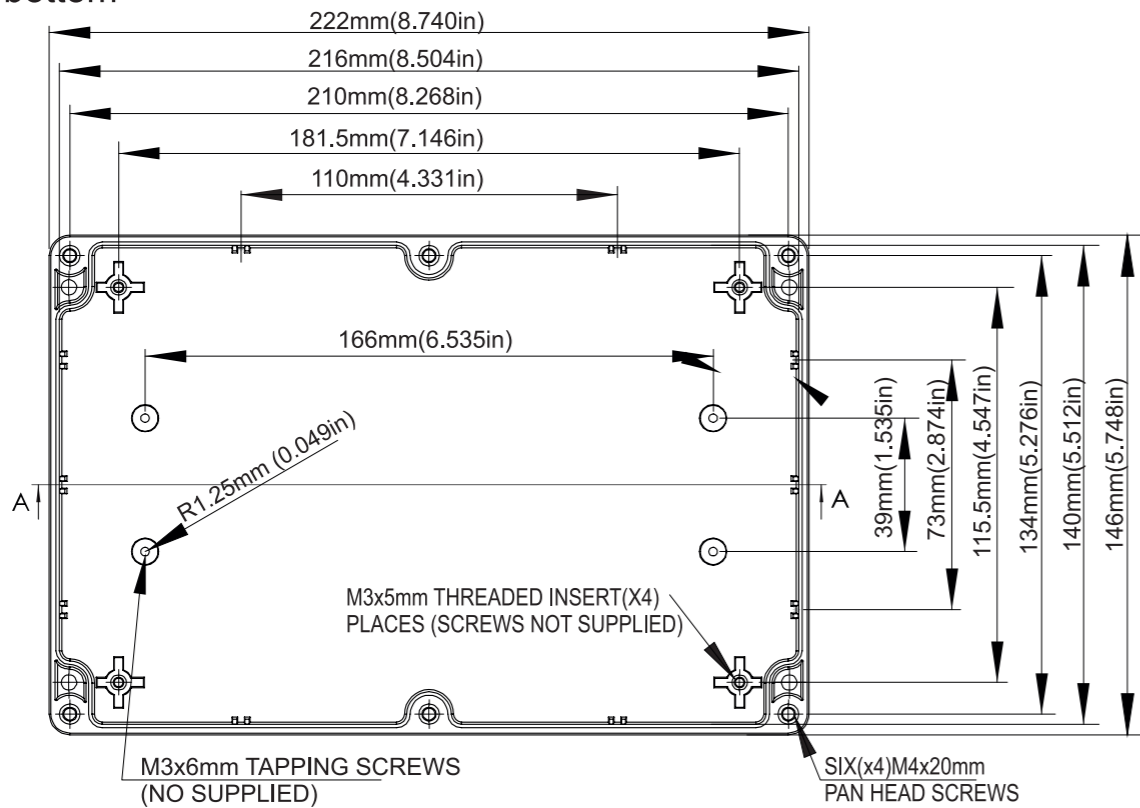

Deckel / cover

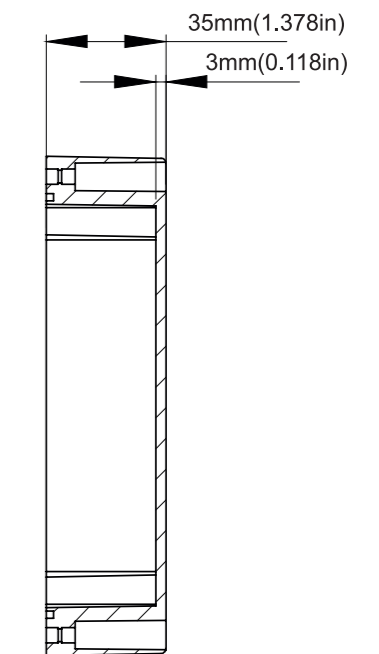
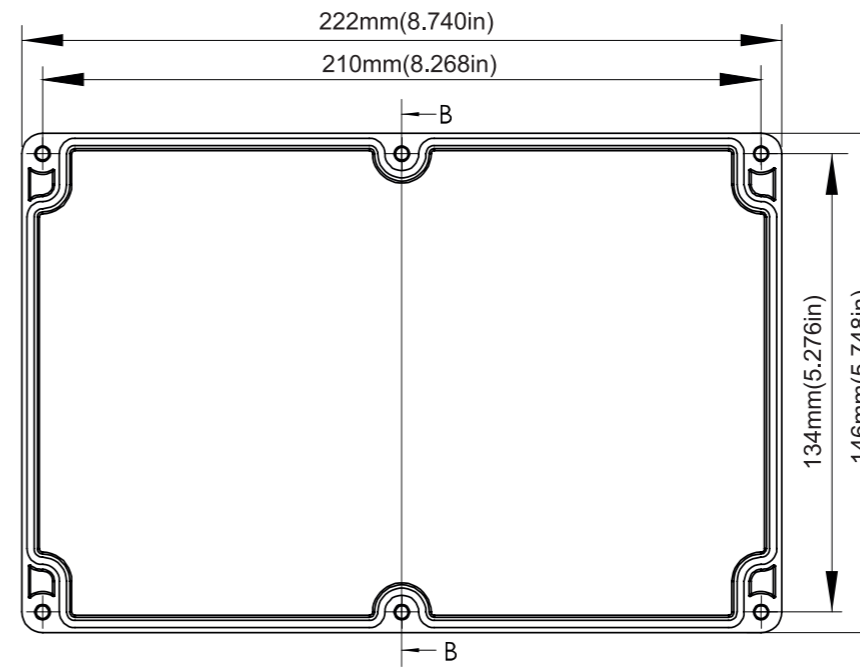

SECTION B-B

Dichtung/sealing

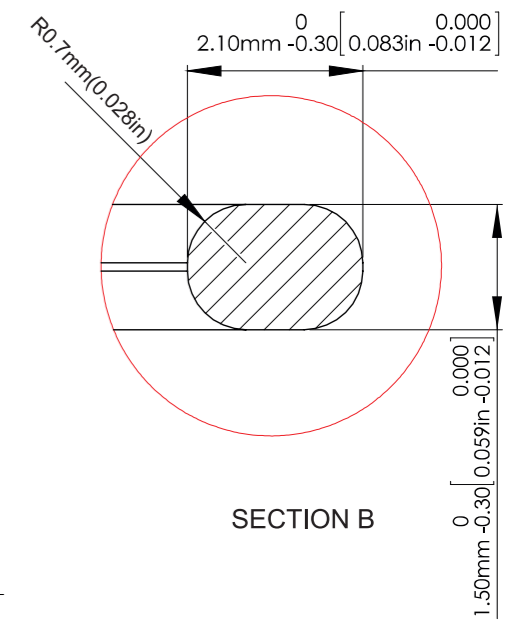

SECTION B

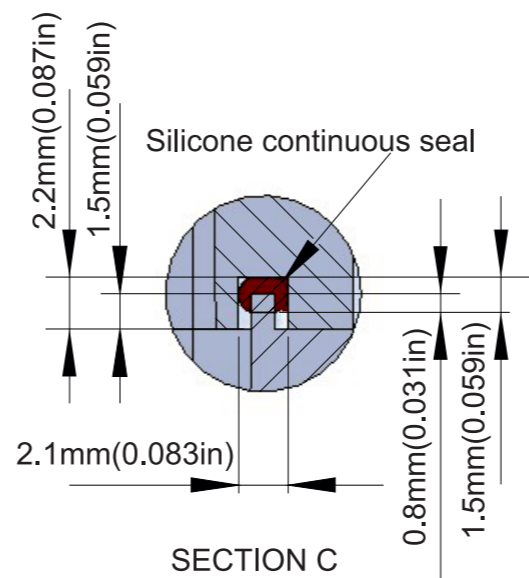

SECTION C

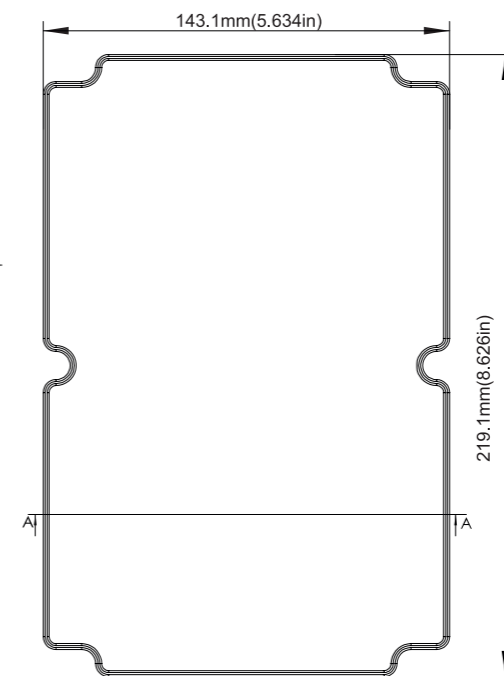

SECTION A-A

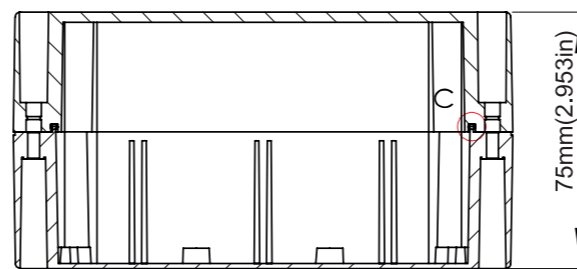

ASSEMBLY

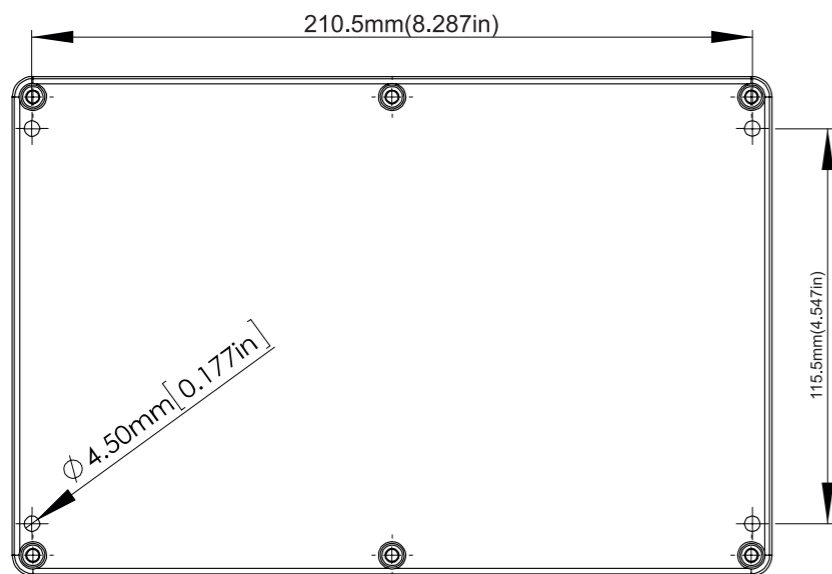

Boden / bottom

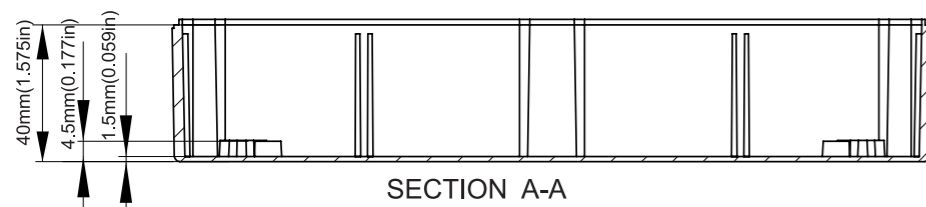

SECTION A-A

According to ISO 2768-m

Measuring DIM=L	Tolerances
0.5<L<=3.0mm	±0.1mm
3.0<L<=6.0 mm	±0.1mm
6.0<L<=30.0 mm	±0.2mm
30.0<L<=120.0 mm	±0.3mm
120.0<L<=400.0 mm	±0.5mm
400.0<L<=1000.0 mm	±0.8mm

**RICHARD
WÖHR**
GMBH

Gräfenau 58-60
D-75339 Höfen / Enz

Telefon (07081) 9540-0
Telefax (07081) 9540-90
Richard@WoehrGmbH.de
www.WoehrGmbH.de

Bezeichnung: /Expression
Industriegehäuse
industrial enclosure

Artikel-Nummer:

GH02KS002/100IP68
GH02KS002/500IP68

Maße in
mm
dimensions
are in mm

Version:
26.05.2020