

Deckel

* = Mass durch Formkonizität nach unten verringert.
Freimass - Toleranz nach DIN 16901-130

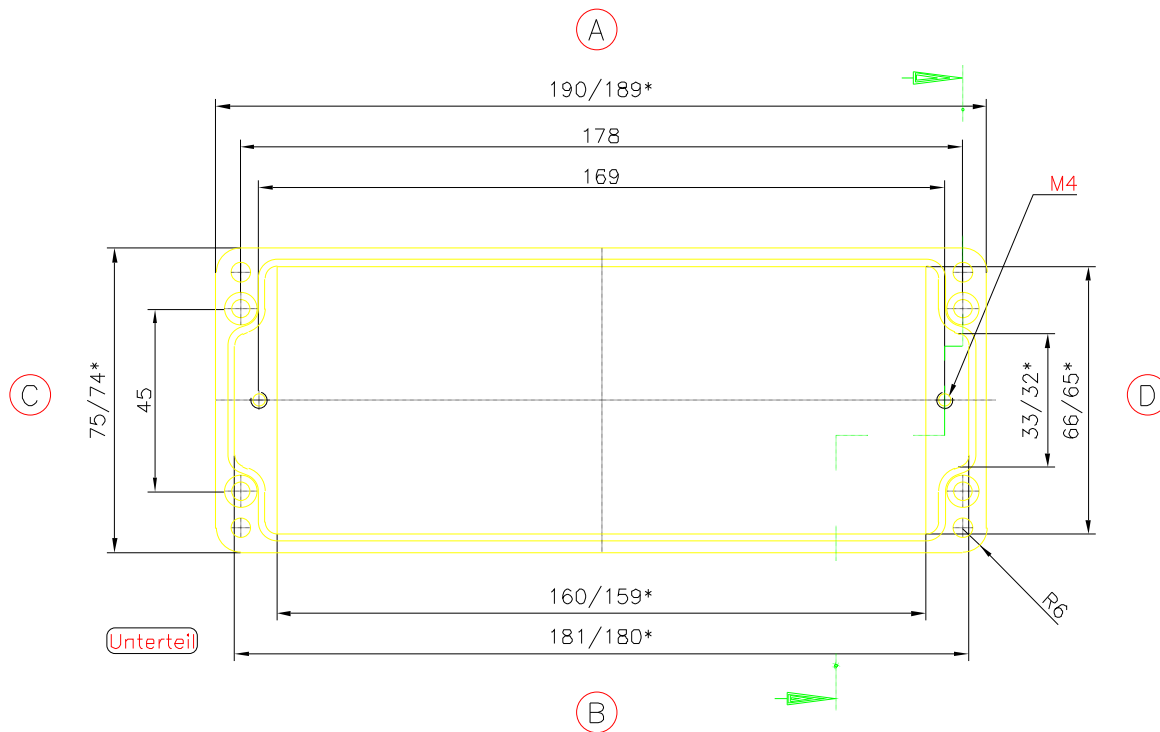

Unterteil

