

Ansicht F

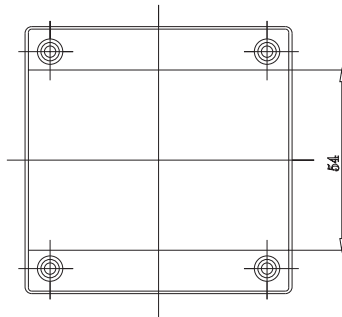

* = Mass durch Formkonisität nach unten verringert.
Freimass - Toleranz nach GTA 19/5 DIN 1688

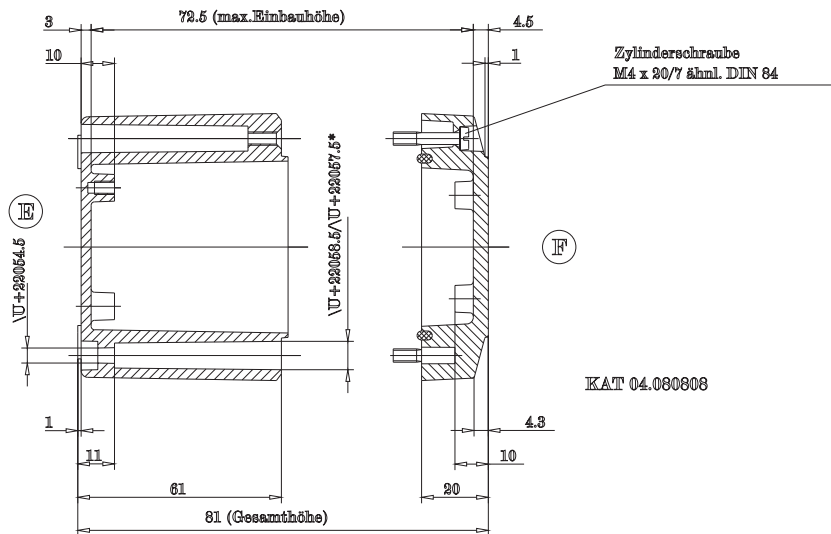
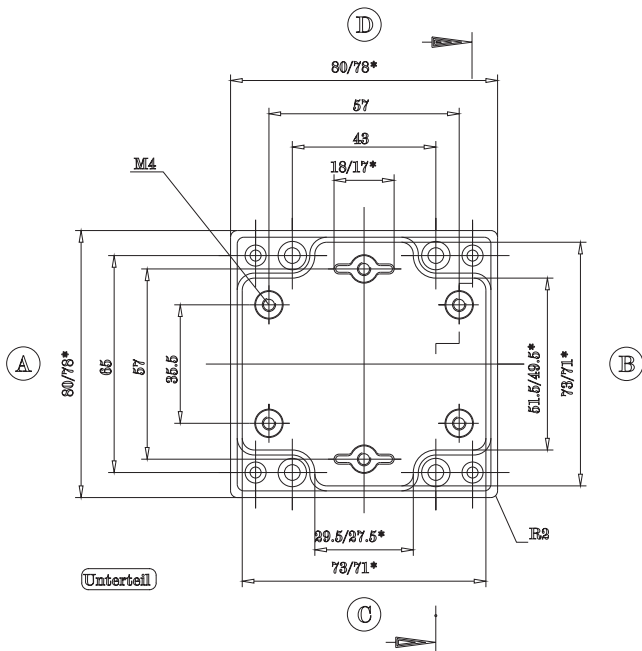
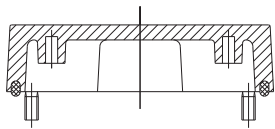

KAT 04.080808

GH02AL005/010

Maße in mm