

* = Mass durch Formkonizität nach unten verringert.
 Freimass - Toleranz nach GTA 13/5 - DIN 1688

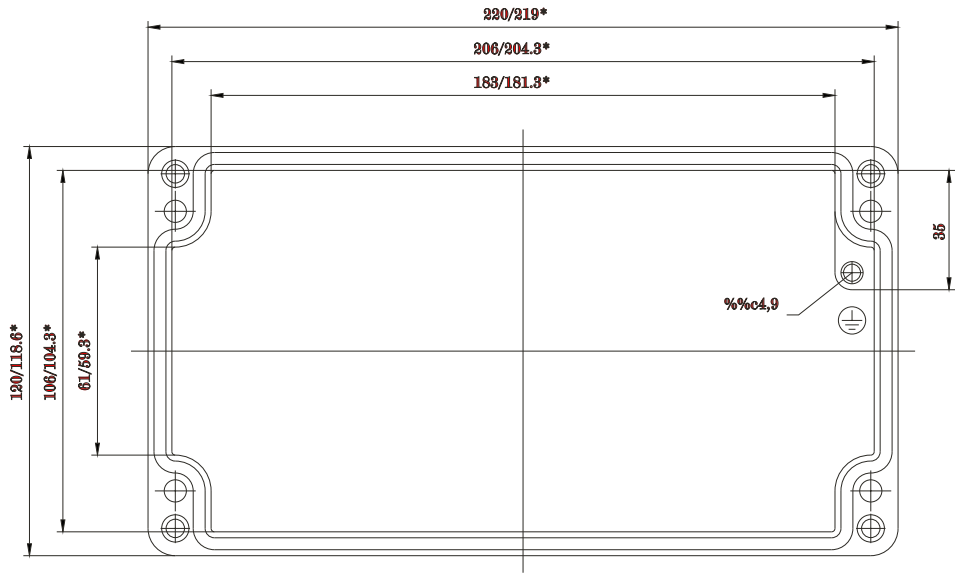

Deckel

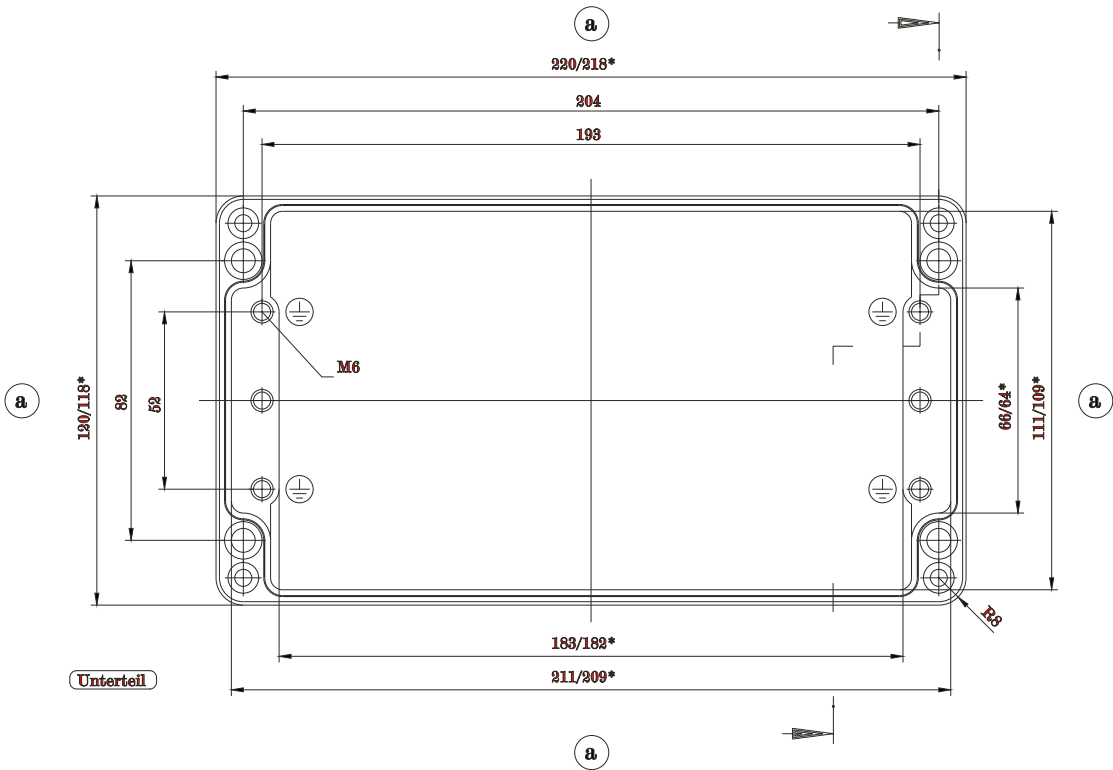

Unterteil

